



ТЕПЛОСОЮЗ

*Возобновляемые
источники
энергии*

Общество с Ограниченной Ответственностью

«ТЕПЛОСОЮЗ»

ИНН/КПП: 7719897336/771901001

Р/с: №40702810538000017562

ОАО Сбербанк России г.Москва

К/с: №30101810400000000225

БИК 044525225



AG-AA10-30

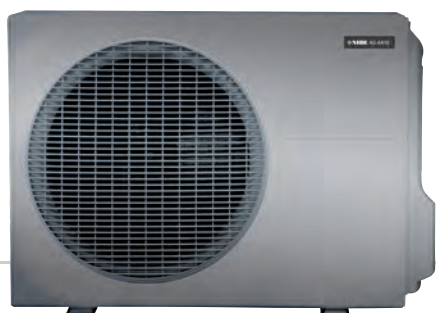

AG-AA10-40/50

Installer manual

AG-AA10

Air/air heat pump

Table of Contents

1 Important information _____	2	5 Installation _____	7
Safety information _____	2	Model combinations _____	7
Read before starting the installation _____	3	Installation instructions _____	7
Electrical requirements _____	3	Pump down _____	11
2 Delivery and handling _____	4	6 The main functions of the valves _____	12
Transport _____	4	7 Disturbances in comfort _____	13
Assembly _____	4	Troubleshooting _____	13
Supplied components _____	4	8 Accessories _____	14
3 Pipe connections _____	5	9 Technical data _____	15
General _____	5	Dimensions _____	15
Connecting the cooling circuit _____	5	Technical specifications _____	16
4 Electrical connections _____	6	Index _____	18
General _____	6		
Connecting indoor and outdoor unit _____	6		
Connecting accessories _____	6		

1 Important information

Safety information

This manual describes installation and service procedures for implementation by specialists.

This appliance can be used by children aged from 8 years and above and persons with reduced physical, sensory or mental capabilities or lack of experience and knowledge if they have been given supervision or instruction concerning use of the appliance in a safe way and understand the hazards involved. Children shall not play with the appliance. Cleaning and user maintenance shall not be made by children without supervision.

Rights to make any design or technical modifications are reserved.

©NIBE 2015.

Symbols



NOTE

This symbol indicates danger to machine or person.



Caution

This symbol indicates important information about what you should observe when maintaining your installation.



TIP

This symbol indicates tips on how to facilitate using the product.

Marking

AG-AA10 is CE marked and fulfills IPX4.

The CE marking means that NIBE ensures that the product meets all regulations that are placed on it based on relevant EU directives. The CE mark is obligatory for most products sold in the EU, regardless where they are made.

IPX4 means that the product is protected against drops of water from all angles.

Environmental information

This unit contains a fluorinated greenhouse gas that is covered by the Kyoto agreement.

F-Gas Regulation (EU) No. 517/2014

The equipment contains R410A, a fluorinated greenhouse gas with a GWP value (Global Warming Potential) of 2087.50. DO not release R410A into the atmosphere.

Safety precautions



NOTE

- Avoid the use and storage of flammable liquids near the climate unit.
- Never install electric equipment that does not have IPX1 protection (protection against vertical water drops), under the unit.

The manufacturer assumes no liability, if safety the standards or protection preventive measures are not complied with.

Special safety measures

During installation the cooling circuit must be connected first and then the electrical circuit. Perform in reverse order when removing the unit.

During repair

- Disconnect the voltage (via the main switch) before opening the unit to check or repair the electrical parts.
- Keep hands and clothing away from moving parts.
- Clean after completing the work, and check that no metal residue or cable parts have been left inside the unit.
- Vent the premises during the installation and the cooling circuit test. Ensure that no refrigerant gas has leaked out during the installation, as contact with naked flames or heat sources can be toxic or dangerous.

Read before starting the installation

This heat pump complies with strict safety and function standards.

It is very important that the installer or the service technicians install or repair the system so that it works safely and efficiently.

For a safe installation and good function the following is required:

- Read this instruction manual carefully before starting installation.
- Follow the installation and safety instructions exactly as described and shown.
- Comply with local and national electrical regulations.
- Note all the warning and safety messages indicated in this manual.
- The unit must be connected to a separate supply.

These instructions are sufficient for installation and maintenance. If assistance is required for a particular problem, contact our dealer for further information.

NIBE does not accept any responsibility for damage that occurs in the event of incorrect installation or improper maintenance.

Electrical requirements



NOTE

- The electrical discharge can cause serious personal injury or death. Only qualified electricians may handle the electrical system.

- Before installation ensure that the mains supply for the power supply is the same as that indicated on the climate unit's rating plate.
- Each unit must be connected with approved grounded cable.
- The electrical connections must be performed by a specially trained and qualified electrician.
- Ensure a ground connection before the unit is powered.
- Hazardous electrical voltage is used in this electrical circuit. See electrical wiring diagram and its instructions below the connection. Incorrect connections or unsuitable ground connection can cause accidents or death.
- The yellow/green cable must not be used for connections other than ground.
- Tighten the cables securely. Incorrect connections can cause overheating and fire.
- Electrical cables must not come into contact with the cooling pipes, the compressor or fan's moving parts.
- Use separate cables for each type of cable.

2 Delivery and handling

Transport

Take care when lifting and moving the indoor and outdoor unit. We recommend that you ask for assistance and bend your knees when you lift to avoid injuring your back. There is a risk of cutting yourself on the sharp edges of the climate unit.

Assembly

We recommend that this climate unit be installed by an authorised technician in accordance with the supplied installation instructions.



NOTE

- Do not install this climate unit where there are flue gases, flammable gases or a lot of moisture, e.g. in a greenhouse.
- Do not install this climate unit where there is equipment that generates too much heat.
- Do not install the unit in premises where it may be subjected to water splashes (e.g. laundry rooms).
- To protect the climate unit from corrosion, the unit must not be installed where it can be directly exposed to seawater splashes or sulphur fumes.

Selection of installation location for outdoor unit

During installation...

- ...in damp or uneven locations:
 - Use a base that is stable and raised above the ground to prevent damage and abnormal vibrations.
- ...in locations exposed to strong winds:
 - Secure the unit with bolts and metal frame. Ensure that there is suitable wind protection.
- ...in locations susceptible to snowfall (for climate units with heat pump):
 - The concrete foundation or slabs must be positioned so that the lower edge of the evaporator is at the level of the average local snow depth, however a minimum of 300 mm.

Prevent the following:

- proximity to heat sources or to areas where hot air is blown out.
- Installation on wooden wall, because there is a risk of resonance.
- damp areas or easily flooded areas and uneven surfaces.
- to drill holes in the areas where there are electrical parts or units.

The following is recommended:

- If possible, select well-ventilated, shaded areas.
- Secure the unit securely at the base to prevent vibrations.

Installation area

Minimum working and maintenance range (measured in mm):

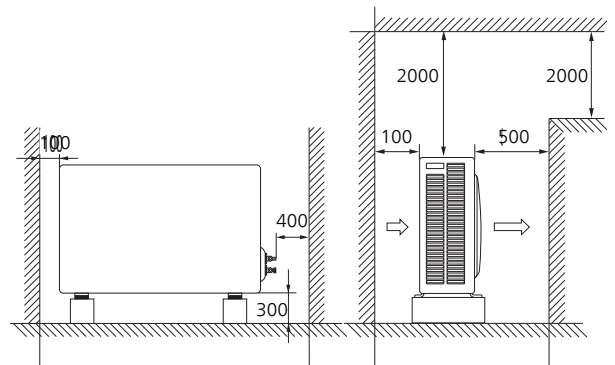

Supplied components

AG-AA10-30/40/50:

- 1 x Communication cable (8.5 m)

3 Pipe connections

General

Pipe installation must be carried out in accordance with current norms and directives.

Only use refrigerant pipes that are seamless, degreased, deoxidized and suitable for a pressure of at least 42 bar. The pipes must be supplied with at least 8 mm vapour-proof insulation.

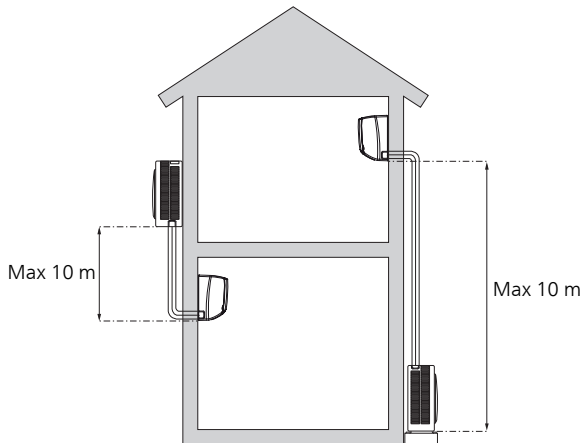

Pipe length	
The refrigerant pipes' minimum length	1.5 m
The refrigerant pipes' total length with standard filling	7.5 m
The refrigerant pipes' total length with additional filling ¹	15 m

¹ 1. Additional filling of refrigerant can be done when the unit runs in cooling operation:

For refrigerant pipe 1/4" - 3/8" = 15 g/m

For refrigerant pipe 1/4" - 1/2" = 20 g/m

For information about pipe dimensions, see section "Technical Specifications" on page 16.

Condensation drain

For condensation removal, the AG-CH10 accessory of sufficient length is required to transport the condensation to an external drain. See section "Accessories" on page 14 for further information about AG-CH10.

Connecting the cooling circuit

- Use the flare method to connect the pipes.
- Lubricate the contact surfaces and hand tighten, then tighten the connections using a torque wrench to obtain a good and secure connection, see installation instructions on page 8.
- Check carefully that there is no risk of any leakage prior to the function test.

4 Electrical connections

General

- A heat pump must not be connected without the permission of the electricity supplier and must be connected under the supervision of a qualified electrician.
- Electrical installation and wiring must be carried out in accordance with the stipulations in force.
- If a miniature circuit-breaker is used this should have motor characteristic "C" (compressor operation). For other fuse sizes, see section "Technical Specifications" on page 16.
- AG-AA10 does not include an omnipolar circuit breaker on the incoming power supply. The heat pump's supply cable must be connected to a circuit breaker with a breaking gap of at least 3 mm. When the building is equipped with an earth-fault breaker the heat pump should be equipped with a separate one. Incoming supply must be 230 V ~ 50 Hz via electrical distribution units with fuses.
- If an insulation test is to be carried out in the building, disconnect the heat pump.

Connecting indoor and outdoor unit

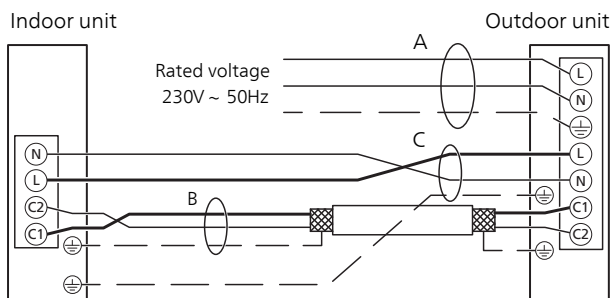

Explanation

A Power supply cable

B Communication cable¹

C Connection cable

¹ The communication cable must **always** be screened. 8.5 m screened cable supplied.

Connecting accessories

The outdoor unit is equipped for connection of a condensation water pipe (AG-CH10).. Connect the power supply to AG-CH10 as illustrated:

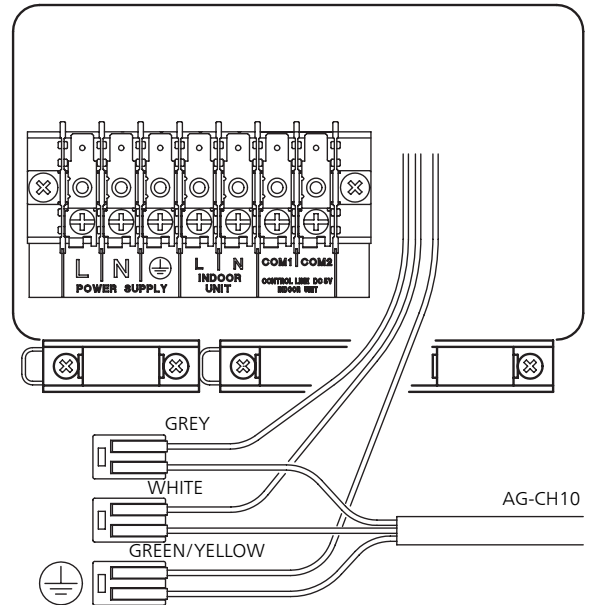

Caution

Also see the Installer manual for AG-CH10.

5 Installation

Model combinations

See product catalogue for further information about model combinations.

Outdoor unit	Indoor unit
AG-AA10-30	AG-WT10-4
AG-AA10-40	AG-WT10-4
AG-AA10-50	AG-WT10-7

Installation instructions

1. Place the outdoor unit on a stable base raised above the ground and secure it.



TIP

When installing stand, install screws downward to facilitate removal of the front panel.

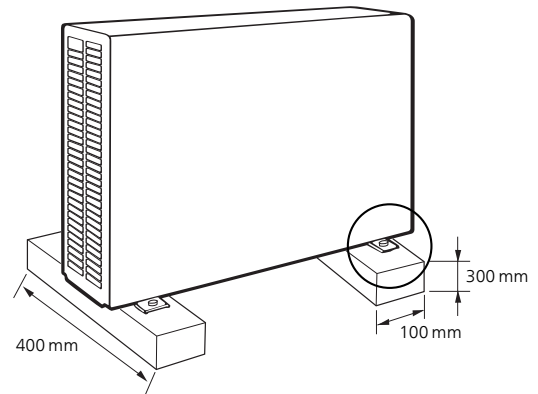

2. Hole for connecting the accessory AG-CH10.

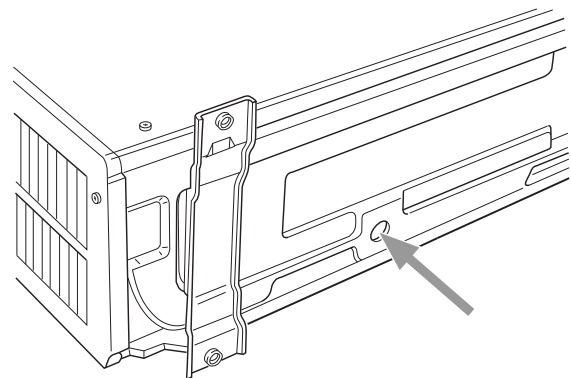

3. Remove the side panel, then connect the supply and communication cables to the outdoor unit and secure them with load relief.

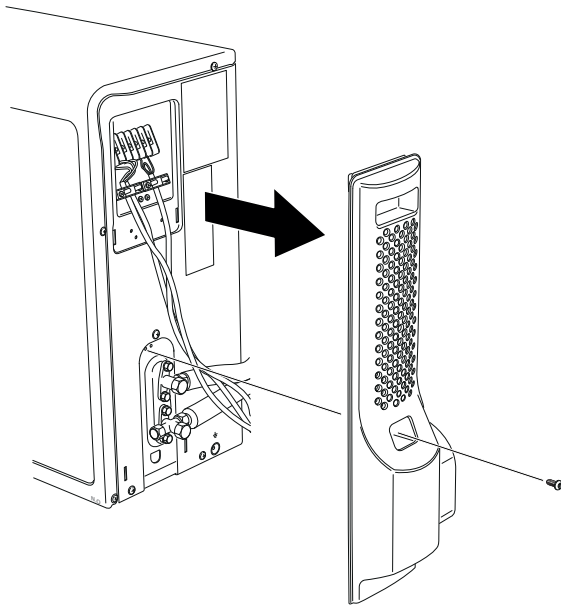

4. Use insulated copper cooling pipes. Cut a length of 30 – 50 cm in addition to the distance between the units.

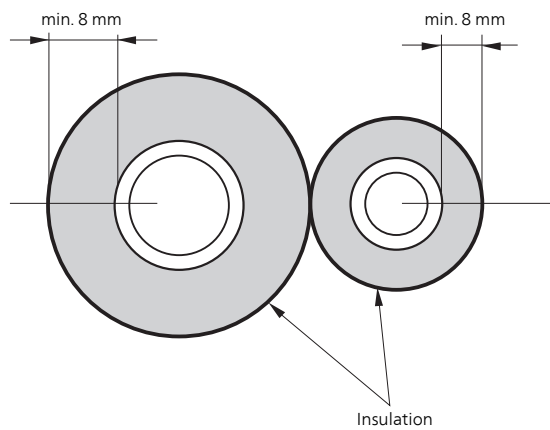

5. Remove burrs from the pipe ends. Turn the pipe ends downwards to prevent residue entering the pipe.

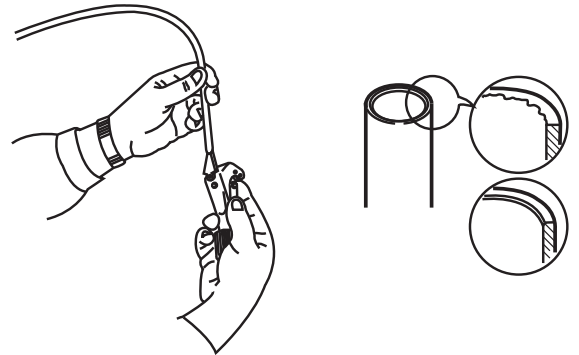

6. Thread the flange nuts (which are removed from the outdoor unit) on the pipes and bend up the ends of the pipes.

NOTE
Only use tools intended for R410A

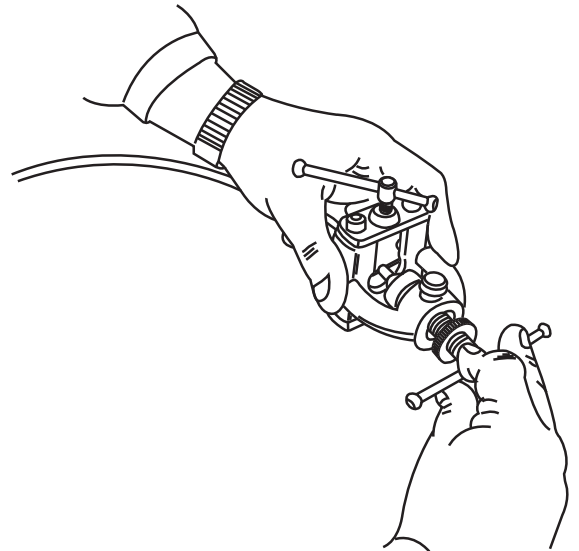

7. A good upward bend must have the following properties:

- a smooth and even inner surface
- a uniform and even outer edge
- a conical upward bend of uniform length.

Lubricate the contact surfaces with compressor oil before connecting the pipes.

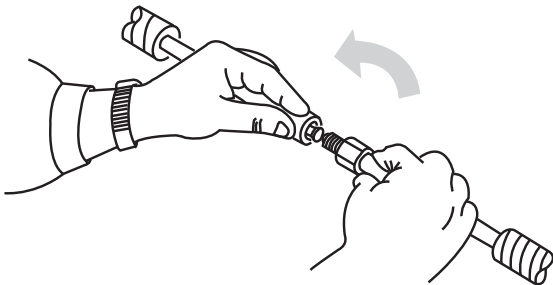
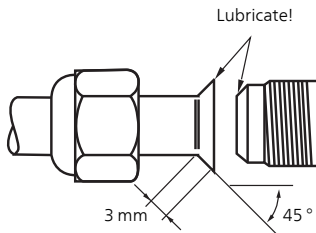

8. Tighten the connections using a wrench and torque wrench according to the tightening torque values in the table.

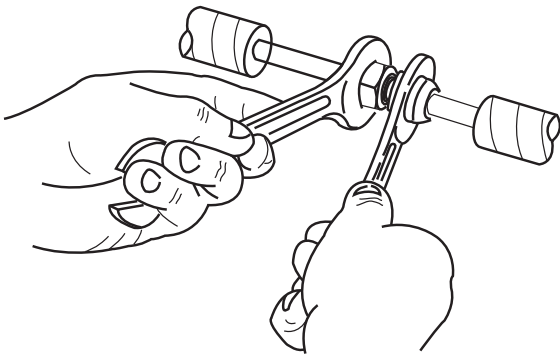

Pipe diameter	Tightening torque
6.35 mm (1/4")	Approx. 15 – 20 Nm
9.52 mm (3/8")	Approx. 30 – 40 Nm
12.7 mm (1/2")	Approx. 50 – 55 Nm
15.88 mm (5/8")	Approx. 60 – 65 Nm

9. Insulate the pipes thoroughly and keep the pipe connections free for leak testing.

Before vacuuming, leak trace the system. Fill with nitrogen to approx. 3 bar. Leak trace all connections using leak spray (soapy water) to ensure that the system is sealed.

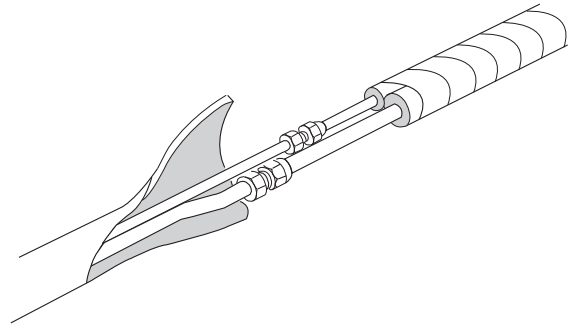

10. For vacuuming of the indoor unit and refrigerant pipe, connect the vacuum pump to the outdoor unit as illustrated.

NOTE
 Remaining air or damp affects the heat pump's function negatively and can damage the product.

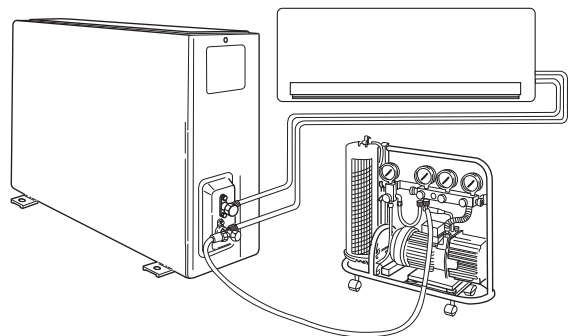

- Remove the valve caps from both valves. Now start the vacuum pump. If damp air has entered the cooling pipes, flush through with dry nitrogen.

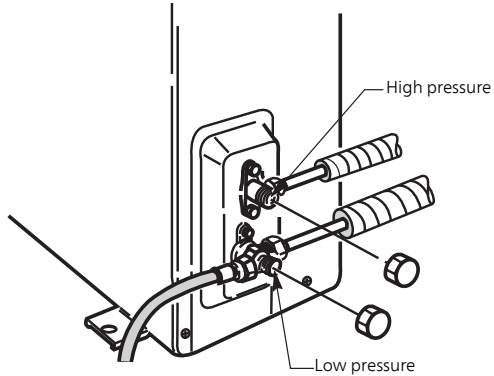

- With the vacuum pump in operation, close the tap on the manometer unit when you have reached a vacuum less than 2 mbar (absolute pressure, standing vacuum min. 30 minutes). Stop the vacuum pump.

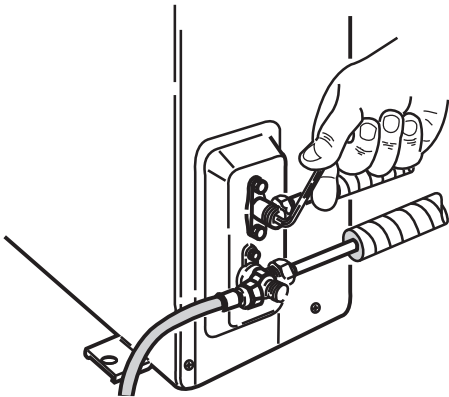

- Open the service valves fully (anti-clockwise direction). Disconnect the vacuum pump. Reinstall the caps on the valves, tighten to a torque of 20 Nm. Leak trace caps and connections using a sniffer or leak spray. See page 12 for the valves' main functions.

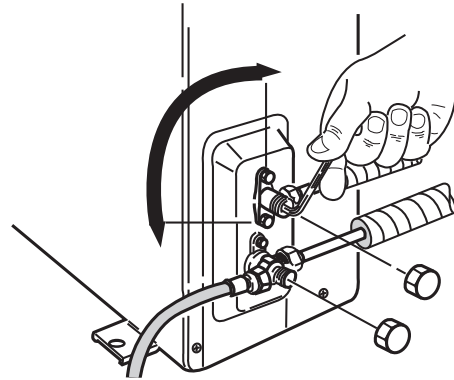

- Complete insulation, protect against mechanical impacts, secure and hang up. If necessary, seal the valve opening in the wall.

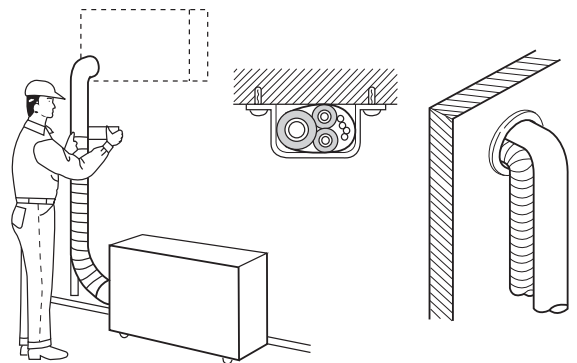

Pump down

Pump down means retrieving all refrigerant in the outdoor unit without losing the system's filling. This is done when the climate unit is to be moved or during repair of the cooling circuit.

Procedure for "Pump down":

1. Connect a manometer assembly to the low pressure valve, open partially (1/4 turns). Extract air from the manometer. Then close the high pressure valve fully.

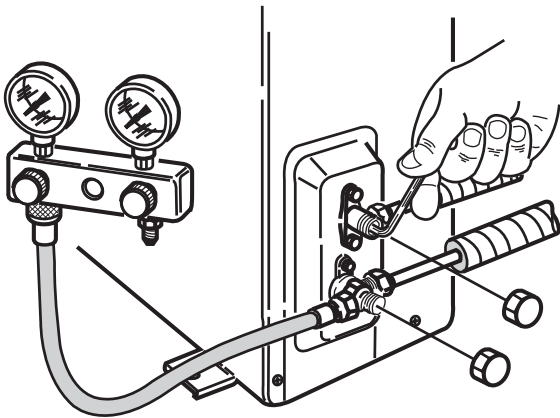

2. Start the climate unit in cooling mode. When the pressure that is read out from the manometer has dropped to a value less than 0.6 bar (absolute pressure), the low pressure valve must be closed fully and the climate unit switched off.

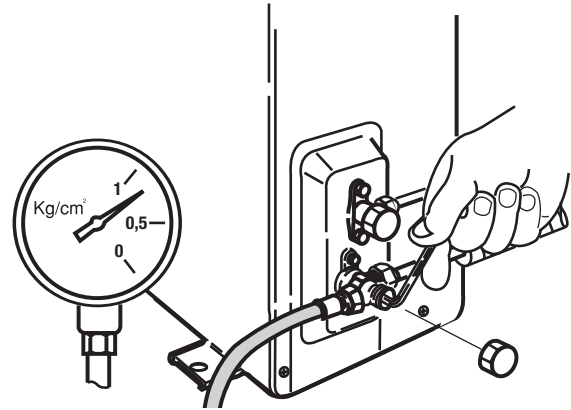

3. Remove the manometer assembly. The action "Pump down" is now complete and all refrigerant has been collected in the outdoor unit.

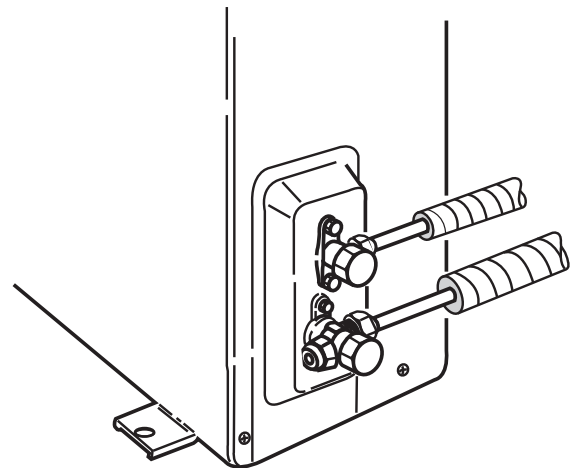

6 The main functions of the valves

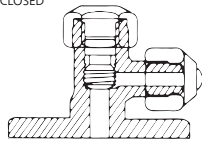
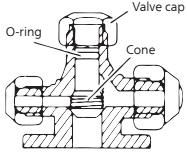
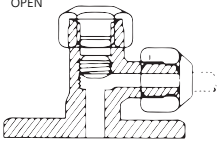
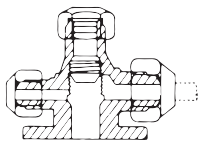
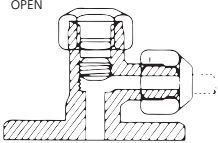
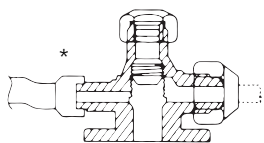
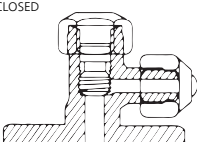
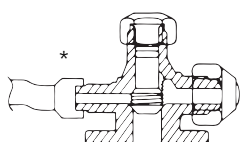
Action	2-way valve (service valve)	3-way valve (service valve)
Delivery	<p>CLOSED</p> 	
Function and test of the climate unit	<p>OPEN</p> 	
Pressure measurement and gas filling	<p>OPEN</p> 	
Vacuumping with vacuum pump	<p>CLOSED</p> 	

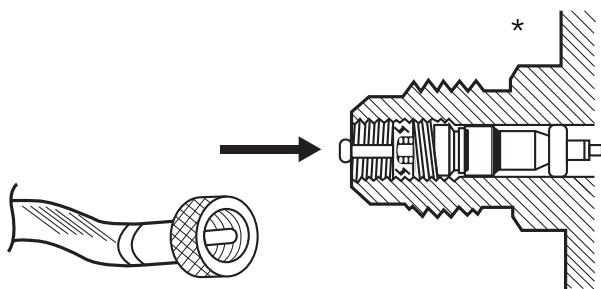

The service valve on the outdoor unit that gives access to the refrigerant system is of the "Schrader" type. Use hoses that have a Schrader opener in the connection.

7 Disturbances in comfort

Troubleshooting



NOTE

Work behind covers secured by screws may only be carried out by, or under the supervision of, a qualified installation engineer.



NOTE

As AG-AA10 can be connected to several different indoor units, these should also be checked.



NOTE

In the event of action to rectify malfunctions that require work within screwed hatches the incoming electricity must be isolated at the safety switch.

Basic actions

Start by checking the following possible fault sources:

- That the climate unit is running or that the supply cable to AG-AA10 is connected.
- Group and main fuses of the accommodation.
- The property's earth circuit breaker.

Fault codes



Caution

Remove the side panel that protects the terminal blocks to read off the LEDs. See page 8.

Key to symbols

○	The LED is off.
◐	The LED flashes.

DL3	DL4	DL5	DL6	DL7	Cause
○	◐	○	○	○	Compressor sensor defective or not connected.
○	○	◐	○	○	Outdoor temperature sensor defective or not connected.
○	○	○	◐	○	Evaporator sensor defective or not connected.
○	○	○	○	◐	Overcurrent on compressor.
◐	◐	○	○	○	The compressor's control electronics have overheated.
○	◐	◐	○	○	Overcurrent on fan.
○	○	◐	◐	○	The fan's control electronics have overheated.
○	○	○	◐	◐	Fault in indoor unit.
◐	◐	◐	○	○	Communication error.
○	◐	◐	◐	○	Phase monitor tripped.

When the unit functions correctly DL3 lights with a steady light. DL4 lights with a steady light if the indoor unit is running, otherwise the lamp is out.

8 Accessories

Condensation water pipe

Condensation water pipe for leading condensation to external drain.

AG-CH10-10

Length: 1000 mm

Part no. 067 466

AG-CH10-30

Length: 3000 mm

Part no. 067 467

AG-CH10-60

Length: 6000 mm

Part no. 067 468

Ground stand

Ground stand AG-GS10-1

Part no. 067 460

Wall mounting

Wall mounting AG-WS10-1

Part no. 067 462

9 Technical data

Dimensions

AG-AA10-30

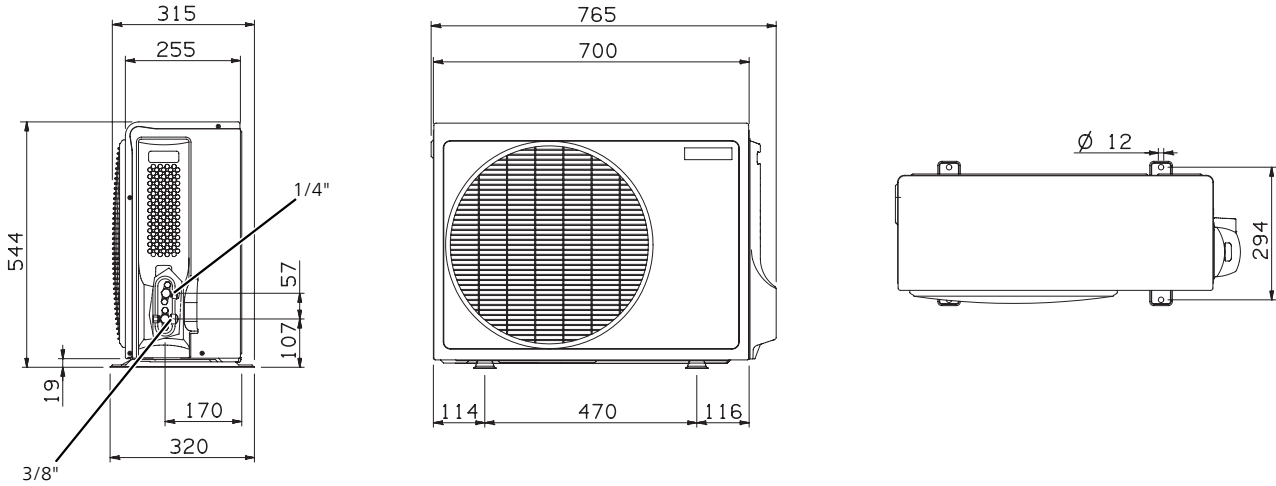

AG-AA10-40/50

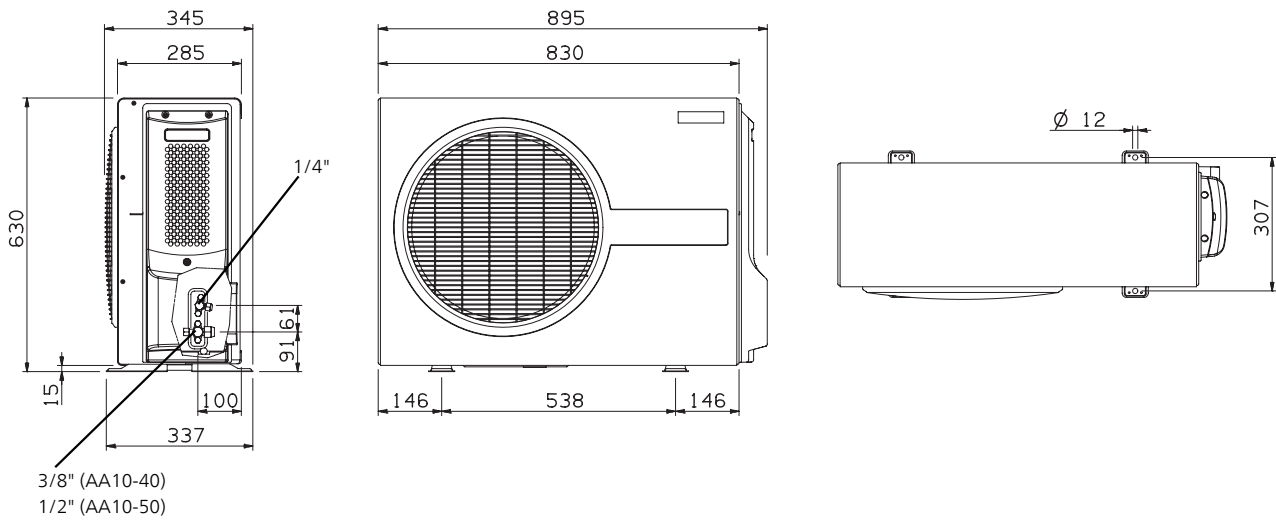

Technical specifications

	AG-AA10-30	AG-AA10-40	AG-AA10-50
Output data			
Cooling capacity +35°C ¹⁾ / 27°C ²⁾ , min/max	1370/3650 W	1010/4060 W	900/5650 W
Heat capacity +7 °C ¹⁾ / +20 °C ²⁾ , min/max	930/3880 W	910/4870 W	1030/5290 W
Heat capacity -7 °C ¹⁾ / +20 °C ²⁾ , max	2650 W	3510 W	3900 W
Heat capacity -20 °C ¹⁾ / +20 °C ²⁾ , max	2150 W	2980 W	3040 W
Pdesignc/SEER/Energy class (cooling +35 °C) ³⁾	2680 W/6.1/A++	3670 W/6.0/A++	5215 W/6.7/A++
Pdesignh/SCOP/Energy class (heat -10 °C) ³⁾	3030 W/3.82/A	4020 W/4.01/A+	4470 W/4.16/A+
Electrical data			
Rated voltage	230 V ~ 50 Hz		
Max. specified power/operating current	1550 W/6.90 A	1550 W/6.90 A	1790 W/7.80 A
Fuse	10 A		
Refrigerant circuit			
Type of refrigerant	R410A		
Type of compressor	Single rotary	Single rotary	Twin rotary
Volume	0.81 kg	1.1 kg	1.3 kg
Pipe connections			
Pipe connection (liquid)	6.35 mm (1/4")	6.35 mm (1/4")	6.35 mm (1/4")
Pipe connection (gas)	9.52 mm (3/8")	9.52 mm (3/8")	12.77 mm (1/2")
Min. thickness refrigerant pipe	0.8 mm	0.8 mm	0.8 mm
Dimensions and weight			
Weight	35 kg	57 kg	57 kg
Width	765 mm	895 mm	895 mm
Depth	315 mm	345 mm	345 mm
Height	544 mm	630 mm	630 mm

	AG-AA10-30	AG-AA10-40	AG-AA10-50
Recommended working range ⁴⁾			
Min/max outdoor temp. during cooling	-20/50 °C		
Min/max indoor temp. during cooling	10/32 °C		
Min/max outdoor temp. during heating	-20/24 °C		
Min/max indoor temp. during heating	0/27 °C		
Miscellaneous			
Max. sound pressure level at 2 m, according to ISO 9614	40 dB(A)	44 dB(A)	41 dB(A)
Enclosure class	IPX4		
Part No.	064 061	064 162	064 163

1) Refers to the outdoor temperature.

2) Refers to the indoor temperature.

3) According to EN 14825

4) Access to full capacity is guaranteed within the heat pumps' recommended working range. Operation outside the recommended working range is possible as the internal protective functions ensure that the heat pump will not be damaged.

10 Item register

Item register

A

Accessories, 14

D

Delivery and handling, 4

Assembly, 4

Transport, 4

E

Electrical connection, 6

I

Important information, 2

Electrical requirements, 3

Safety information, 2

Installation, 7

Installation instructions, 7

Model combinations, 7

Pump down, 11

M

Marking, 2

P

Pipe connections, 5

Condensation removal, 5

Connecting the cooling circuit, 5

S

Safety information

Marking, 2

Symbols, 2

Safety precautions, 2

Supplied components, 4

Symbols, 2

T

Technical data, 15

Dimensions, 15

Technical specifications, 16

The main function of the valves, 12