

# Ventilation heat exchanger NIBE ERS 10-400/ERS 20-250

The NIBE ERS 10-400/ERS 20-250 are heat recovery ventilation units with high temperature efficiency up to 92% and low energy consumption. The NIBE ERS 10 is used in houses with areas up to approx. 300 m<sup>2</sup>, NIBE ERS 20 up to approx. 200 m<sup>2</sup>.

The NIBE ERS 10-400/ERS 20-250 are designed for installation with a NIBE ground source heat pump or a NIBE air/water heat pump for a complete heating and ventilation system. The heat recovery ventilation units are easily controlled by the heat pump.

Thanks to smart technology, the product gives you control over your energy consumption and will be a key part of your connected lifestyle. The efficient control system automatically adjusts the indoor climate for maximum comfort, and you do nature a favour at the same time.

- The heat recovery ventilation units with high temperature efficiency and low energy consumption.
- Together with the NIBE ground source or air/water heat pump, it provides an integrated solution in houses with balanced ventilation.
- Easy to control and part of your smart home in combination with a NIBE heat pump.



# This is how ERS works

## Principle

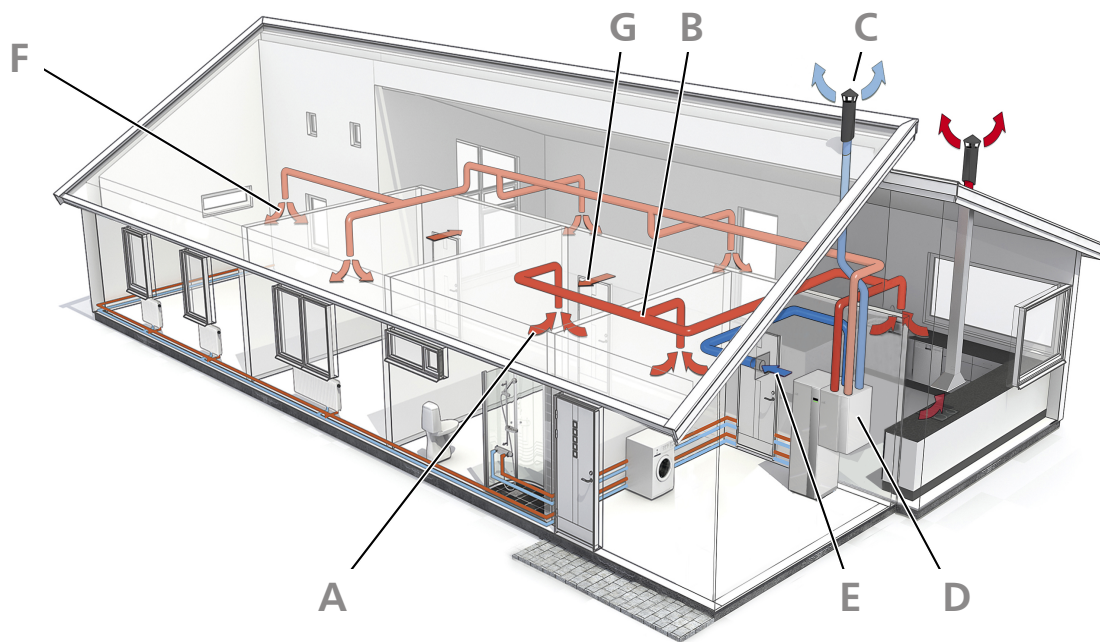

The figure shows ERS 10.

ERS is a ventilation heat exchanger with inbuilt fans and counter-current heat exchanger.

Energy is recovered from the ventilation air and supplied to your home, which reduces energy costs considerably. The unit ventilates the house and heats the supply air as necessary.

The unit is intended for both new installations and replacement in houses or similar.

ERS is suitable for ventilation systems where high temperature efficiency and low energy consumption are required. ERS 10 is normally used in homes with an area of up to approx. 300 m<sup>2</sup>, ERS 20 to approx. 200 m<sup>2</sup>.

- A** The warm room air is drawn into the air duct system.
- B** The warm room air is fed to ERS.
- C** The room air is released when it has passed ERS. The air temperature has then been reduced as ERS has extracted the energy in the room air.
- D** ERS ventilates your home and heats the supply air.
- E** Outdoor air is drawn into ERS and heated if necessary.
- F** Air is blown out into rooms with supply air inlets.
- G** Air is transported from rooms with supply air inlets to rooms with exhaust air valves.

# Good to know about ERS

## Transport and storage

ERS should be transported and stored in the dry.

## Supplied components

### ERS 10

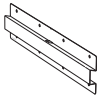

Rail for wall mounting

### ERS 20

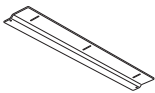

2 x roof brackets

## Installation and positioning

ERS 10 is installed using the enclosed rail on a solid wall. ERS 20 is installed in the roof using the enclosed roof brackets. Noise from the fans can be transferred to the brackets.

- Install ERS 10 with its back to an outside wall, ideally in a room where noise does not matter, in order to eliminate noise problems. Install ERS 20 on an outside wall, ideally in a room where noise does not matter, in order to eliminate noise problems. If this is not possible, avoid placing it against a wall adjoining a bedroom or other room where noise may be a problem.
- Wherever the unit is located, walls to sound sensitive rooms should be fitted with sound insulation.
- Condensation comes from the underside of the ventilation heat exchanger. Condensation outlet with water seal must be installed and routed to an internal drain.
- The ventilation heat exchanger's installation area should always have a temperature of at least 10 °C and max. 35 °C.

## INSTALLATION AREA

### ERS 10

Leave a free space of 800 mm in front of the product.

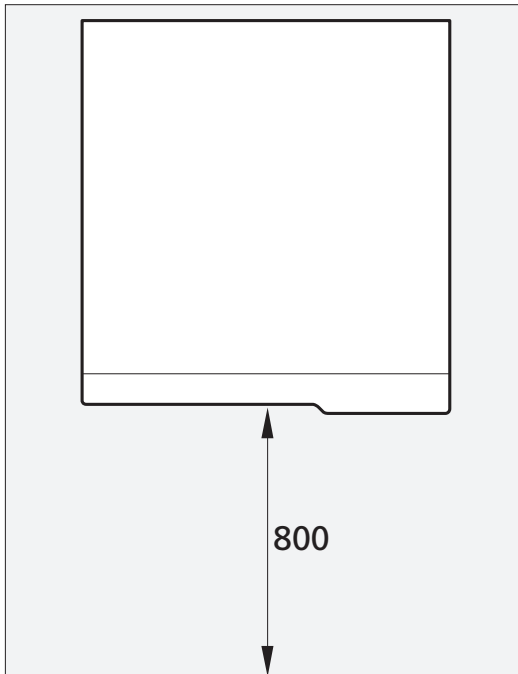

Ensure that there is necessary space (300 mm) above the exhaust ventilation heat exchanger for installing ventilation hoses.

### ERS 20

Leave a free space of 1,000 mm in front of the distribution box and 200 mm in front of the other sides. Because servicing is carried out from underneath, free space of 1,600 mm is recommended below the unit.

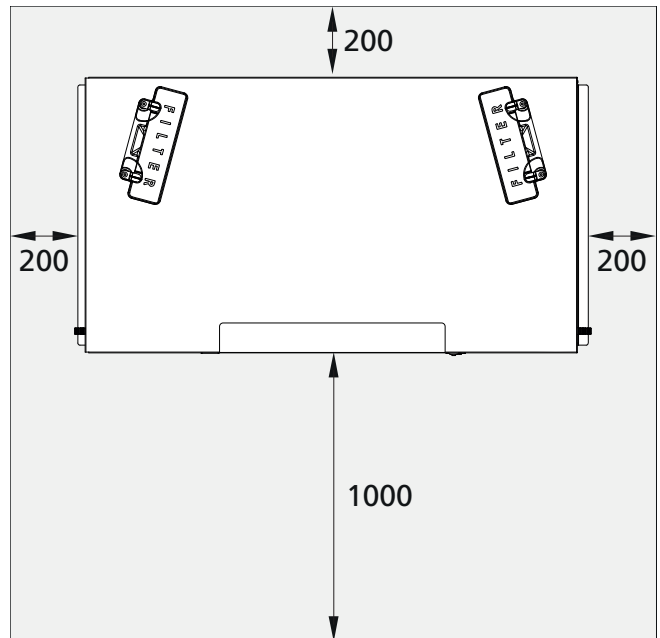

# Installation

## Condensation water drain

ERS can produce several litres of condensation water per day. It is therefore important that the condensation drain is correctly laid out and the unit is installed level.

Check that the water seal is airtight and firmly in position. The connection must be made so that the user can check that the water seal is functioning, without opening ERS.

The connection for the condensation outlet on ERS 20 measures Ø15 mm. On ERS 10, the condensation outlet is adapted for the type of water seal that is traditionally used for a wash basin (connection G32).

## Ventilation

- Connect ERS so that all the exhaust air, except kitchen duct air (kitchen fan), passes through the heat exchanger in the product.
- The ventilation flow must comply with the applicable national standards.
- The supply air flow must be lower than the exhaust air flow to prevent over pressure in the house.
- Connections must be made via flexible hoses, which should be installed so that they are easy to replace.
- The air duct system must be a minimum of air tightness class B.
- To prevent fan noise being transferred to the ventilation devices, silencers should be installed in the duct system. In the event of ventilation devices in noise-sensitive rooms, silencers must be installed.
- When the extract air and outdoor air temperature is/becomes cold, the extract air and outdoor air duct must be insulated using diffusion-proof material (at least PE30 or equivalent) along its entire length.
- Exhaust air ducts that are routed in cold areas must be insulated.
- All joins in the ducting must be sealed to prevent leakage.
- The air must be routed to the outdoor air duct through an outer wall grille in the facade. The outer wall grille must be installed so that it is protected from the weather and must be designed so that no rainwater and/or snow can penetrate the facade or follow the air into the duct.
- When positioning the outdoor air and extract air hood/grille, bear in mind that the two air flows must not short circuit to prevent the extract air from being drawn into ERS again.
- A duct in a masonry chimney stack must not be used for extract air.

- If a stove or similar is installed, it must have airtight doors. It must also be able to take combustion air from outside.
- Incorrect adjustment of the ventilation may lead to reduced installation efficiency and thus poorer operating economy, and may cause moisture damage in the building

### SETTING THE FAN CAPACITY

Select the ventilation capacity steplessly in the display.

#### Ventilation capacity ERS 10

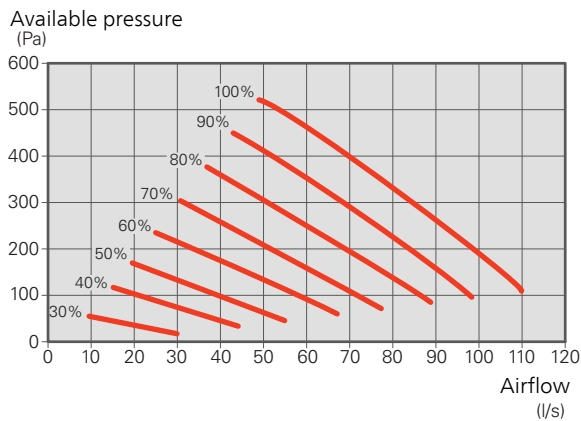

#### Ventilation capacity ERS 20

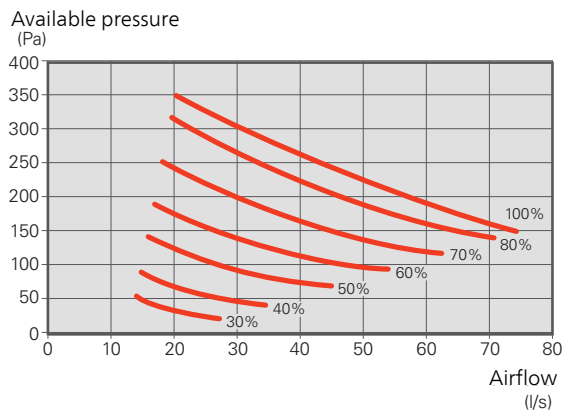

### VENTILATION CONNECTIONS

#### ERS 10

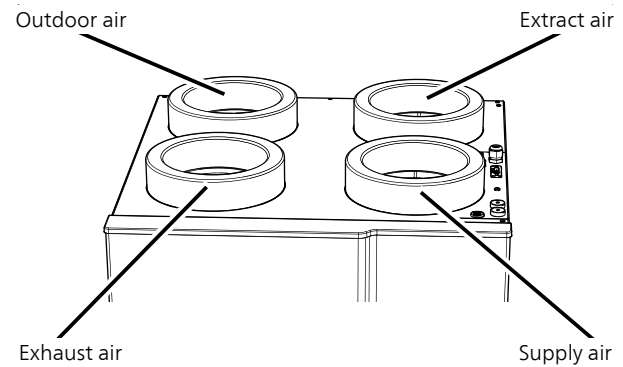

#### ERS 20

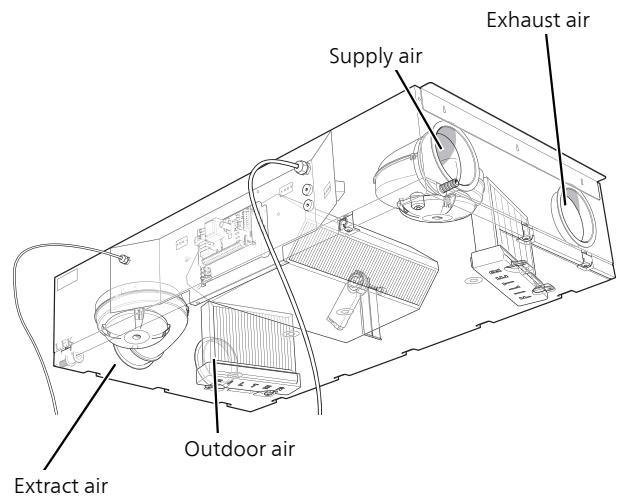

# Electrical connection

## CONNECTING TO MAIN PRODUCT

- Disconnect ERS before insulation testing the house wiring.
- Signal cables to external connections must not be laid close to high current cables.
- If the supply cable is damaged, only NIBE, its service representative or similar authorised person may replace it to prevent any danger and damage.

ERS is equipped with a communication cable from the factory (cable length 2.0 m), which is connected to a circuit board in the heat pump. It is also equipped with a supply cable with a plug (cable length 2.4 m).

Electrical installation and service must be carried out under the supervision of a qualified electrician. Electrical installation and wiring must be carried out in accordance with the stipulations in force.

# Functions



Using the Internet and NIBE Uplink, you can obtain a quick overview and the present status of the installation and the heating in your home.

You can obtain a good overall view, allowing you to monitor and control the heating and hot water comfort effectively. If the system is affected by a malfunction, you receive an alert via e-mail that allows you to react quickly.

NIBE Uplink also gives you the opportunity to control the comfort in your home easily, no matter where you are.

## Range of services

You have access to different levels of service via NIBE Uplink. A basic level that is free and a premium level where you can select different extended service functions for a fixed annual subscription fee (the subscription fee varies depending on the selected functions).

NIBE Uplink also available as an app from App Store and Google Play.



# Technical data

## Dimensions

ERS 10

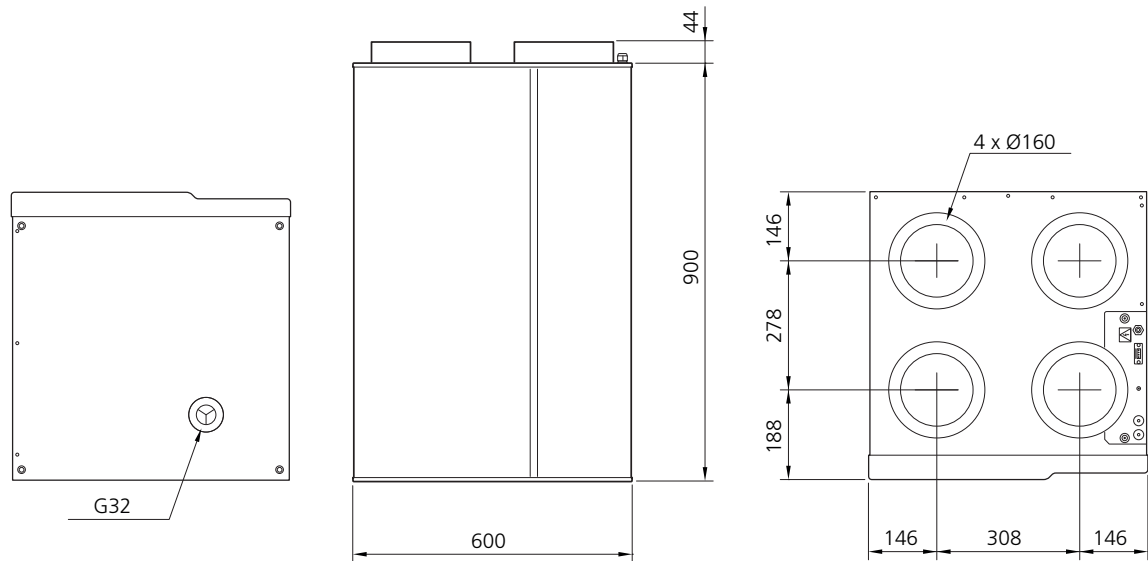

ERS 20

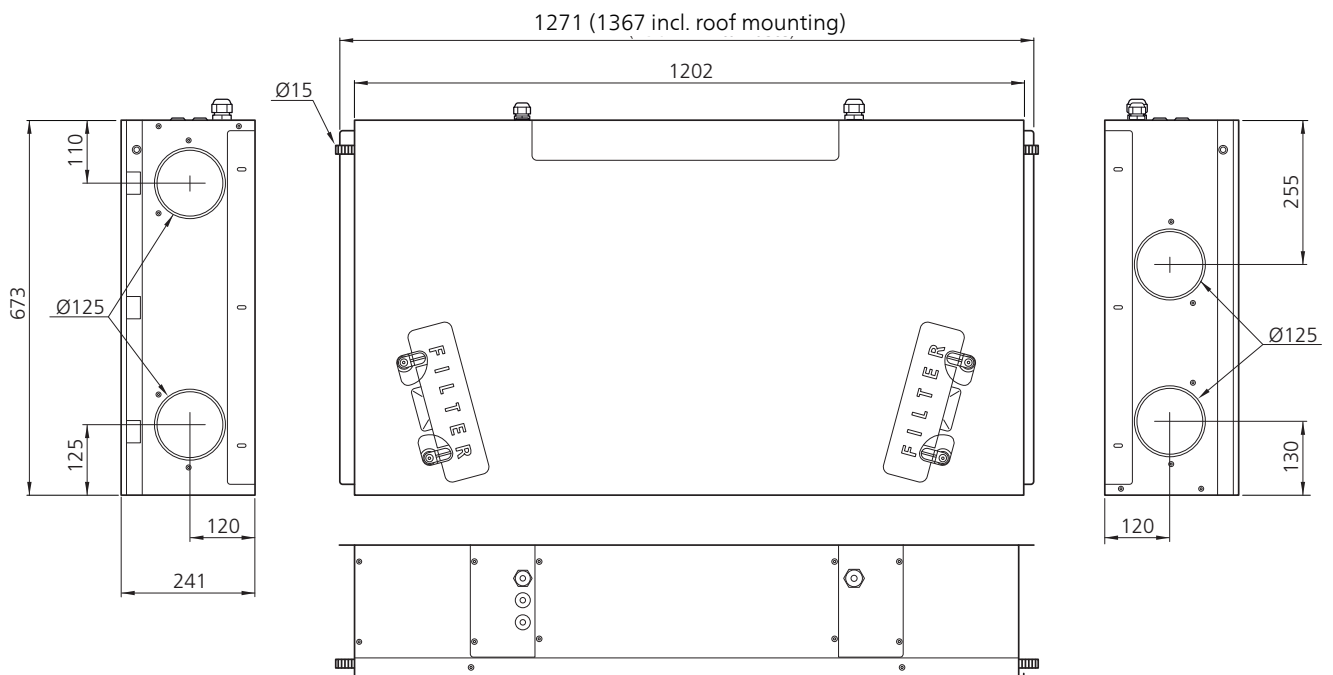

# Technical specifications

Type		ERS 10	ERS 20
<i>Electrical data</i>			
Supply voltage	V	230 V ~ 50Hz	
Fuse	A	10	
Driving power fan	W	2 x 85	2 x 100
Enclosure class		IP 21	
<i>Ventilation</i>			
Filter type, exhaust air filter		G4	
Filter type, supply air filter		F7	F7
<i>Sound pressure levels</i>			
Sound pressure level (L <sub>P(A)</sub> ) <sup>1</sup>	dB(A)	48	-
Sound pressure level (L <sub>P(A)</sub> ) at 1 m <sup>2</sup>	dB(A)	-	47.4
Sound pressure level (L <sub>P(A)</sub> ) at 1 m <sup>3</sup>	dB(A)	-	50.0
<i>Pipe connections</i>			
Ventilation Ø	mm	160	125
Condensation water drain		G32	15 mm
<i>Miscellaneous</i>			
Efficiency class <sup>4</sup>		A	
Length, supply cable	m	2.4	
Length, control cable	m	2.0	
Width	mm	600	1,202
Depth	mm	612	673
Height	mm	900	241
Weight	kg	40	25
Part no.		066 115	066 068

- 1 287 m<sup>3</sup>/h (80 l/s) at 50 Pa
- 2 105 m<sup>3</sup>/h at 50 Pa
- 3 250 m<sup>3</sup>/h at 140 Pa
- 4 Scale for efficiency class: A+ to G.

## ERS 10

Dry temperature efficiency according to EN 308

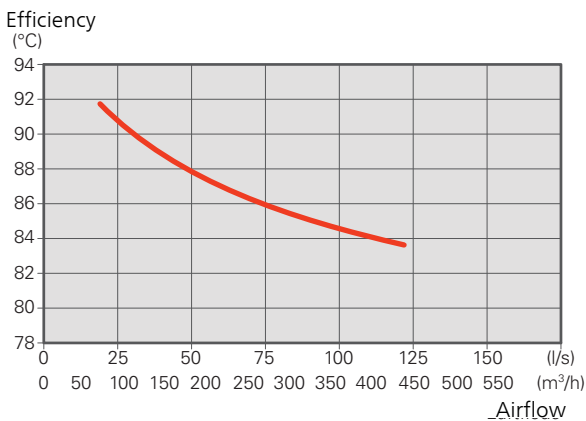

## ERS 20

Dry temperature efficiency according to EN 308

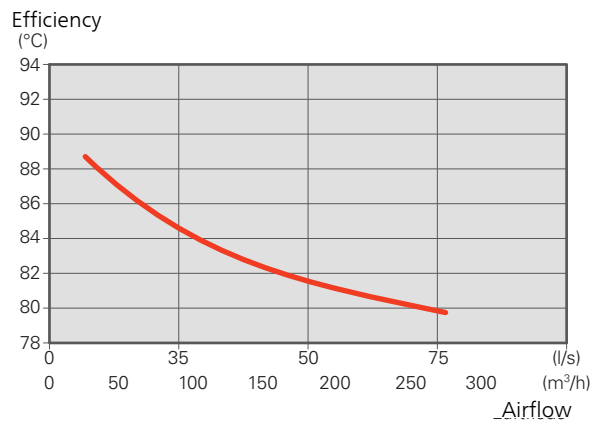

Outdoor air: 5 °C Exhaust air 25 °C RH exhaust air: <27.7 % Outdoor air: 5 °C Exhaust air 25 °C RH exhaust air: <27.7 %

# Accessories

Detailed information about the accessories and complete accessories list available at [nibe.se](http://nibe.se).

## *Electric air heater EAH*

In cold weather, EAH heats the outdoor air slightly to prevent condensation in ERS from freezing. Used mainly in colder climates.

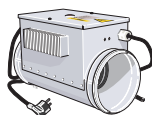

*EAH 10-1800 (450-900 W)*

Part no. 067 567

*EAH 20-900 (300-900 W) EAH 20-1800 (300-1800 W)*

Part no. 067 604

*W)*

Part no. 067 603

## *Top cabinet*

Top cabinet that conceals the ventilation ducts and reduces the sound to the installation room.

*Height 245 mm    Height 445 mm*

Part no. 089 756    Part no. 067 522

*Height 345 mm    Height 385-635*

Part no. 089 757    *mm*

Part no. 089 758

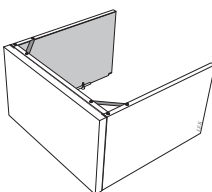

This product sheet is a publication from NIBE Energy Systems. All product illustrations, facts and data are based on current information at the time of the publication's approval. NIBE Energy Systems makes reservations for any factual or printing errors in this product sheet.